

**R.A JONES**

a coesia company

# CMV-150

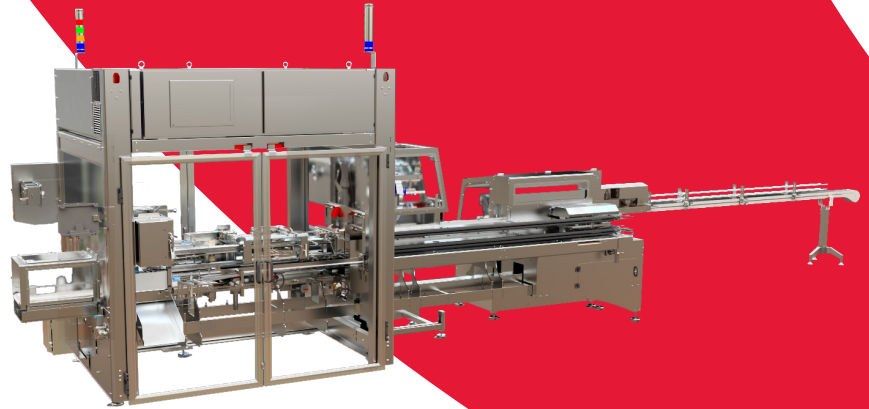

## Continuous Motion Vertical Cartoner

The R.A Jones CMV-150 Vertical Cartoner draws on over 80 years as a product line that defined the packaging category. We have now added new automation capabilities and updated components to the standard features and options that have come to be expected by our customers around the world. The Constant Motion Vertical (CMV) joins together machine simplicity with new technology to load products into the top of carton sizes from small to large at speeds up to 150cpm. Handling various combinations of tuck or glued styled flaps, the CMV-150 produces high-quality, consumer-ready cartons for companies of any size.

With over 2000 machines in service, the flexibility of hand loading products, integrating any number of proven, product loading automation options (e.g., bottles, literature, robots), or combinations of both manual and automated loading solutions will give your organization the technology it needs for long-term success. Labor enhancement and changeover repeatability can also be achieved by adding the Acc-U-Change® option.

## Key benefits

- Based on proven and reliable technology
- Quick return on investment
- Flexibility and future-proofing through various levels of automation
- Supports a wide range of carton sizes and applications
- Expert consultation by R.A Jones

## Fully automated

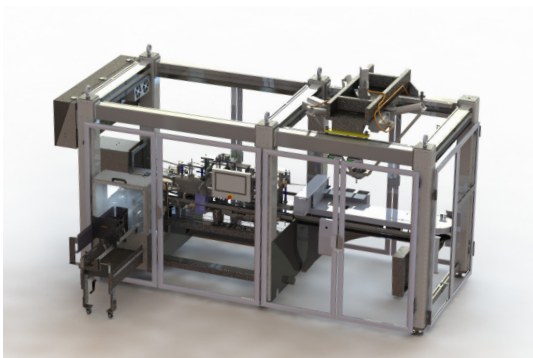

## Hand load

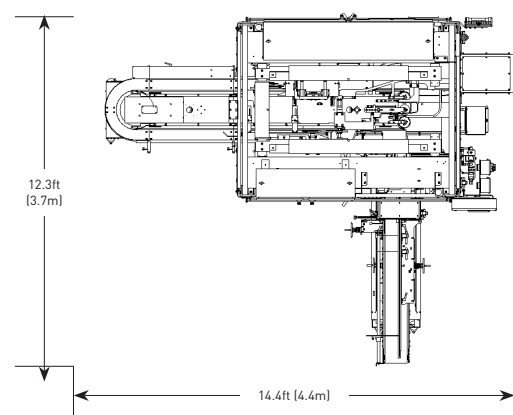

## Features and benefits

- Top Loaded carton (pre-glued side seam)
- Tuck top & bottom flap closing
- Speed: 40 to 150cpm
- Rotary Carton Feed with pre-break, 3 spindle, CMC opening
- 5' Magazine (Std.)
- Four-chain transport, 6" or 9" pitch
- Carbon steel painted and stainless steel frame
- RH or LH configuration
- High/Low enclosure voltage separation
- Beckhoff PLC and Motion Controls
- OptiMate HMI (Base level)

## Options

- Rotary Carton Feed with Phasing Axes & Moving Side Rail for CMH style opening
- Glue top & bottom flap closing
- Automated Loading
- Open flap detect & reject
- Acc-U-Change® Plus for fast carton length and depth changeover
- OptiMate Advanced Level

## Applications

- Food
- Consumer Goods
- Cosmetics
- Nutraceuticals
- Pharmaceuticals
- Automotive
- Electronics
- Personal Hygiene

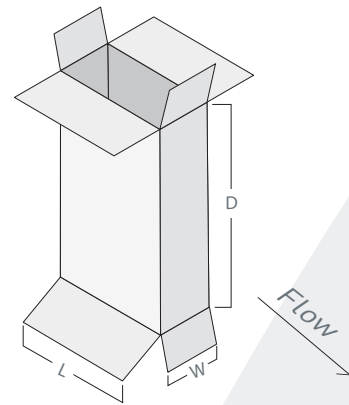

## Standard carton size range

6" Pitch	Minimum	Maximum
<b>Length (L)</b>	1" (25.4mm)	5" (127mm)
<b>Width (W)</b>	1" (25.4mm)	4.25" (108mm)
<b>Depth (D) Std.</b>	3.5" (89mm)	9.25" (235mm)
<b>(D) Max.</b>	4.25" (108mm)	10" (254mm)
<b>(D) Min.</b>	2.5" (63.5mm)	8.25" (210mm)
<b>Speeds</b>	40 cpm	150 cpm

9" Pitch	Minimum	Maximum
<b>Length (L)</b>	1" (25.4mm)	8" (203mm)
<b>Width (W)</b>	1" (25.4mm)	4.25" (108mm)
<b>Depth (D) Std.</b>	3.5" (89mm)	9.25" (235mm)
<b>(D) Max.</b>	4.25" (108mm)	10" (254mm)
<b>(D) Min.</b>	2.5" (63.5mm)	8.25" (210mm)
<b>Speeds</b>	40 cpm	100 cpm

### R.A JONES

2701 Crescent Springs Road  
Covington, KY 41017, USA  
T: 1.800.216.4499

www.rajones.com - info@rajones.com



a coesia company