



a coesia company

Celestion[®] MTX



About the Celestion® MTX

The **Celestion® MTX** is an advanced machine platform built for flexible TopLoad cartoning automation. By seamlessly combining key technologies such as robotics, carton forming, loading, and closing, the platform provides the capability to package products in a variety of ways. The machine layout will typically be in a monobloc configuration that provides a complete and scalable packaging system.

Base machine features

- RH or LH configuration

Carton forming

- Cartons formed from paperboard flat blanks
- One Module (two or four magazines per module)
- Single Module Speed (2 Formers)
- Carton Styles - Full Trifold, Economy Trifold, Inner-Fold, Combo-Fold, Trays, Others

Carton transport

- Intelligent Carton Transport (ICT™)
- Programmable horizontal linear motor transport
- Independent control of each carton allows for variable pitch and motion
- Leading and trailing carts maintain clamping force on carton around complete oval track

Product loading

- Products loaded from the top with standard tooling using a 3-Axis delta robot. (One module shared with carton closing)

Carton closing

- Three-Axis articulating robot with standard or custom tooling (One module shared with product loading)
- Quick change tooling for mounting and utilities
- Glue closure with Nordson hot melt unit and guns standard

Controls

- PLC and Motion Controls: Beckhoff
- High/Low enclosure voltage separation
- HMI: OptiMate (Base level) with Systems Electronics touchscreen IPC

Machine options

- Speeds up to 150 cpm
- Corrugated carton or tray materials
- Advanced carton designs
- Product loading with custom tooling and other robots that could include:
 - 2-Axis (single or twin)
 - 4-Axis delta (adds rotate)
 - Six-Axis
 - Cartesian
- Advanced product collating, grouping, orienting, or secondary products with robots or hard automation
- Advanced product infeed conveyors
- Integrated laser coding
- Literature feeding
- Bottle feeding
- Allen-Bradley controls and PanelView HMI



Consistent • Flexible • Reliable

FLOW

Modular TopLoad Cartoner

Products

Flow wraps

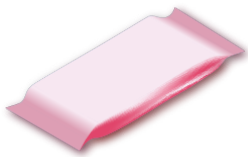

Carton



Rates

Cartons - up to 150 cpm

Products - up to 800 ppm

	Min (mm)	Max (mm)
Length (L)	115	325
Width (W)	130	265
Depth (D)	10	195

FLEX

Modular TopLoad Cartoner

Products

Flexible Pouches



Tray

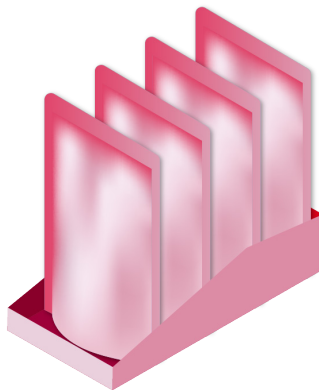

Rates

Cartons - up to 150 cpm

Products - up to 200 ppm

	Min (mm)	Max (mm)
Length (L)	50	250
Width (W)	75	305
Depth (D)	10	265

VISION

Modular TopLoad Cartoner

Products

Bags, Pouches

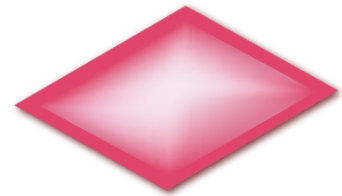

Carton

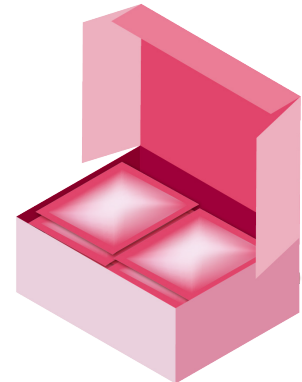

Rates

Cartons - up to 50 cpm

Products - up to 500 ppm

	Min (mm)	Max (mm)
Length (L)	180	250
Width (W)	120	250
Depth (D)	5	180

Consistent • Flexible • Reliable

VARIETY

Modular TopLoad Cartoner

Products

Bars, Bags, Pouches*

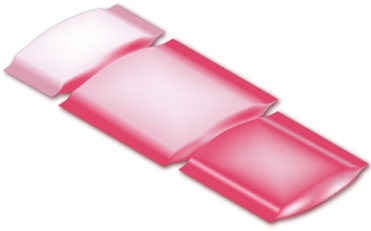

Carton



*1 to 4 flavors

Rates

Cartons - up to 150 cpm

Products - up to 800 ppm

	Min (mm)	Max (mm)
Length (L)	115	325
Width (W)	125	305
Depth (D)	5	200

KIT

Modular TopLoad Cartoner**

Products

Various

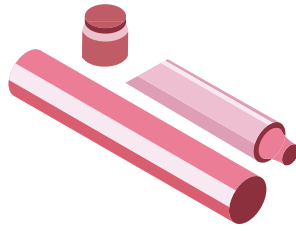

Tray

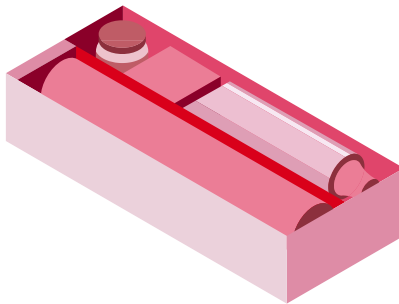

**Consult for carton, tray and lid ranges

Rates

Cartons - up to 150 cpm

Products - up to 800 ppm

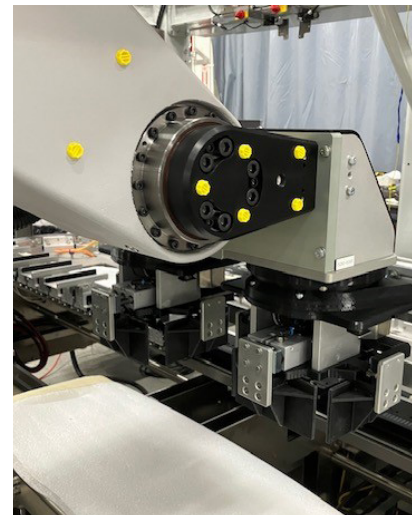
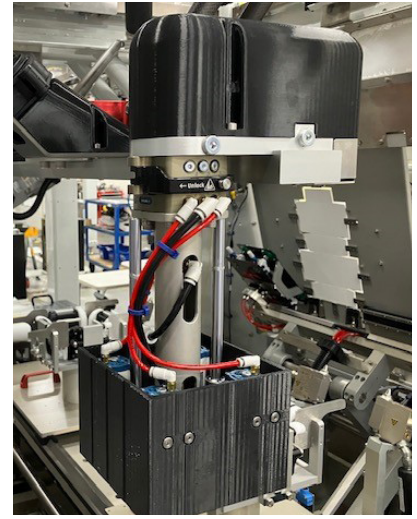
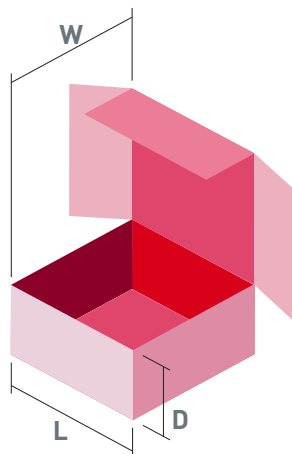

Machine configurations

The building blocks

Combine standard **Celestion® MTX** functional modules to meet your production needs. Build the machine or system that you need! (M - Modular, T - TopLoad, X - Platform)

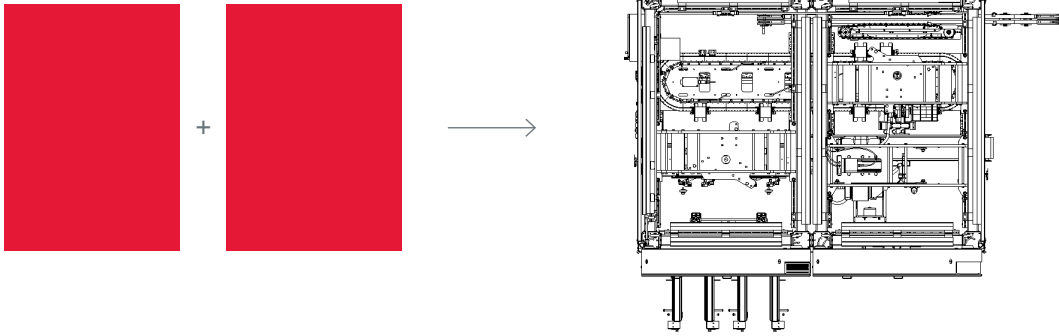

FLOW

The **Celestion® MTC - FLOW** combines carton forming, carton loading with infeed and collation modules for wrapped products, and carton closing all connected by the intelligent carton transport system. (M - Modular, T - TopLoad, C - Cartoning)

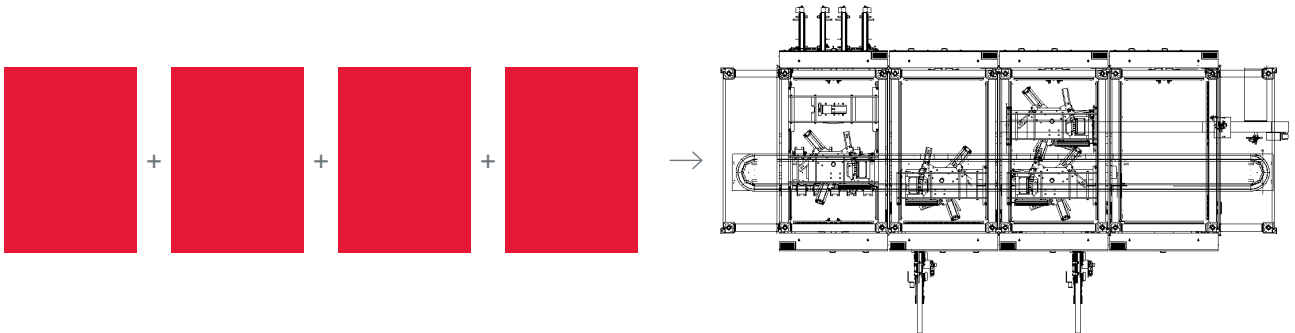

FLEX

The **Celestion® MTC - FLEX** combines carton forming, carton loading with a collation module for pouches, and carton closing along with the intelligent carton transport system.

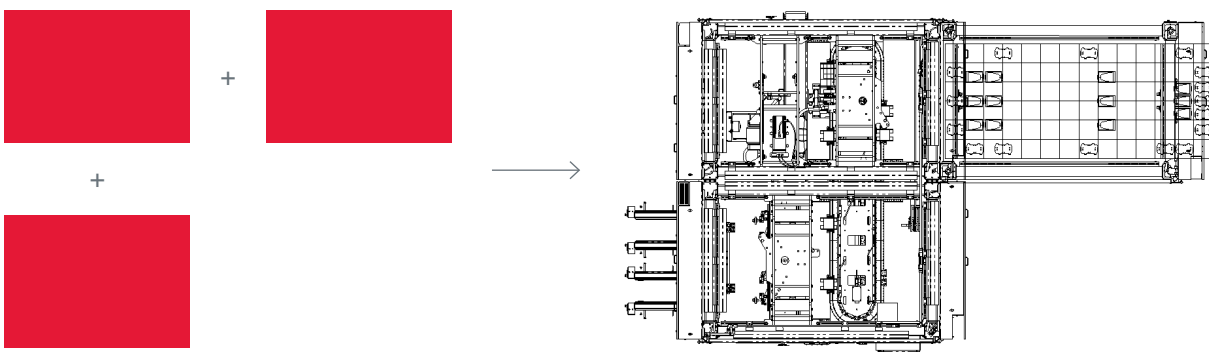

VISION

The **Celestion[®] MTC - VISION** combines carton forming, a best-in-class vision system and co-flow carton loading approach by PWR, a continuous motion carton transport, and carton closing.

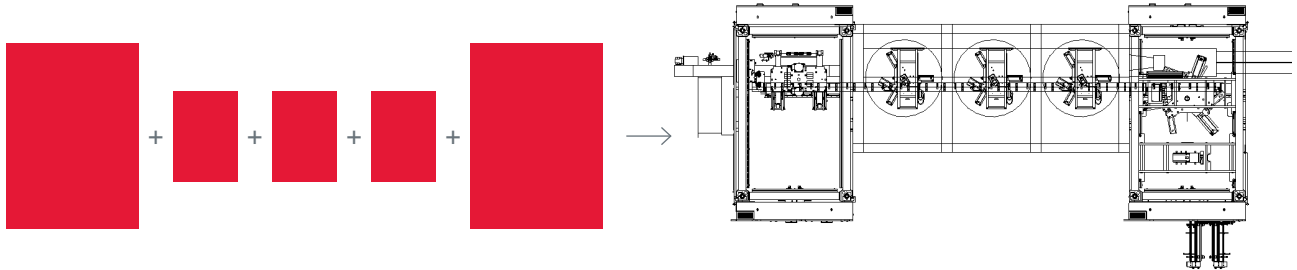

VARIETY

The **Celestion[®] MTC - VARIETY** solves the variety pack labor and logistics issue with a complete Coesia solution. Coesia partner company **PWR** provides bulk dump sortation of 1 to 4 flavors or bars, pouches, or bags delivered to the Celestion[™] MTC. Celestion[™] MTC - VARIETY combines carton forming, carton loading with infeed and collation modules, carton closing, and the intelligent carton transport system.

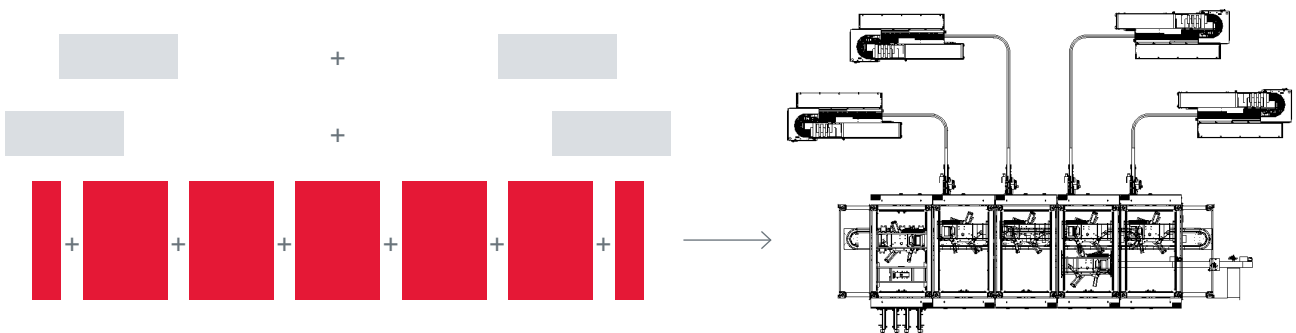

KIT

The **Celestion[®] MTC - KIT** handles multi-component product and literature combination challenges using standard or custom modules. Cartons, unique compartmented trays, attached or independent lids, and more are possible with this flexible system.

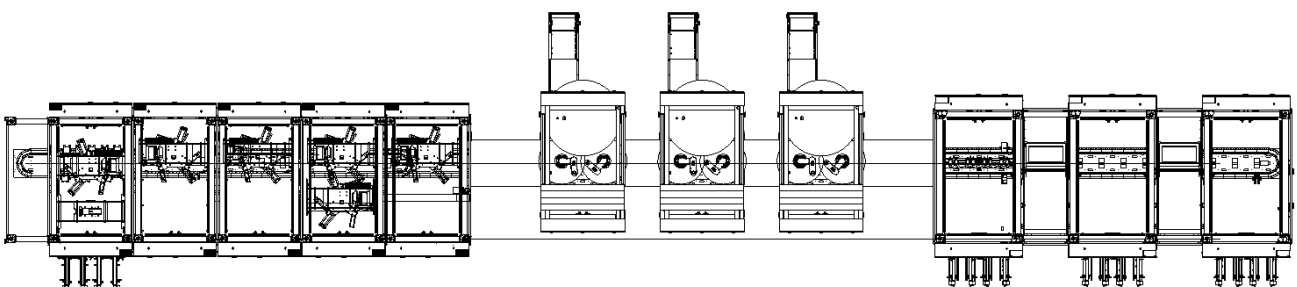

Coesia Group in the world

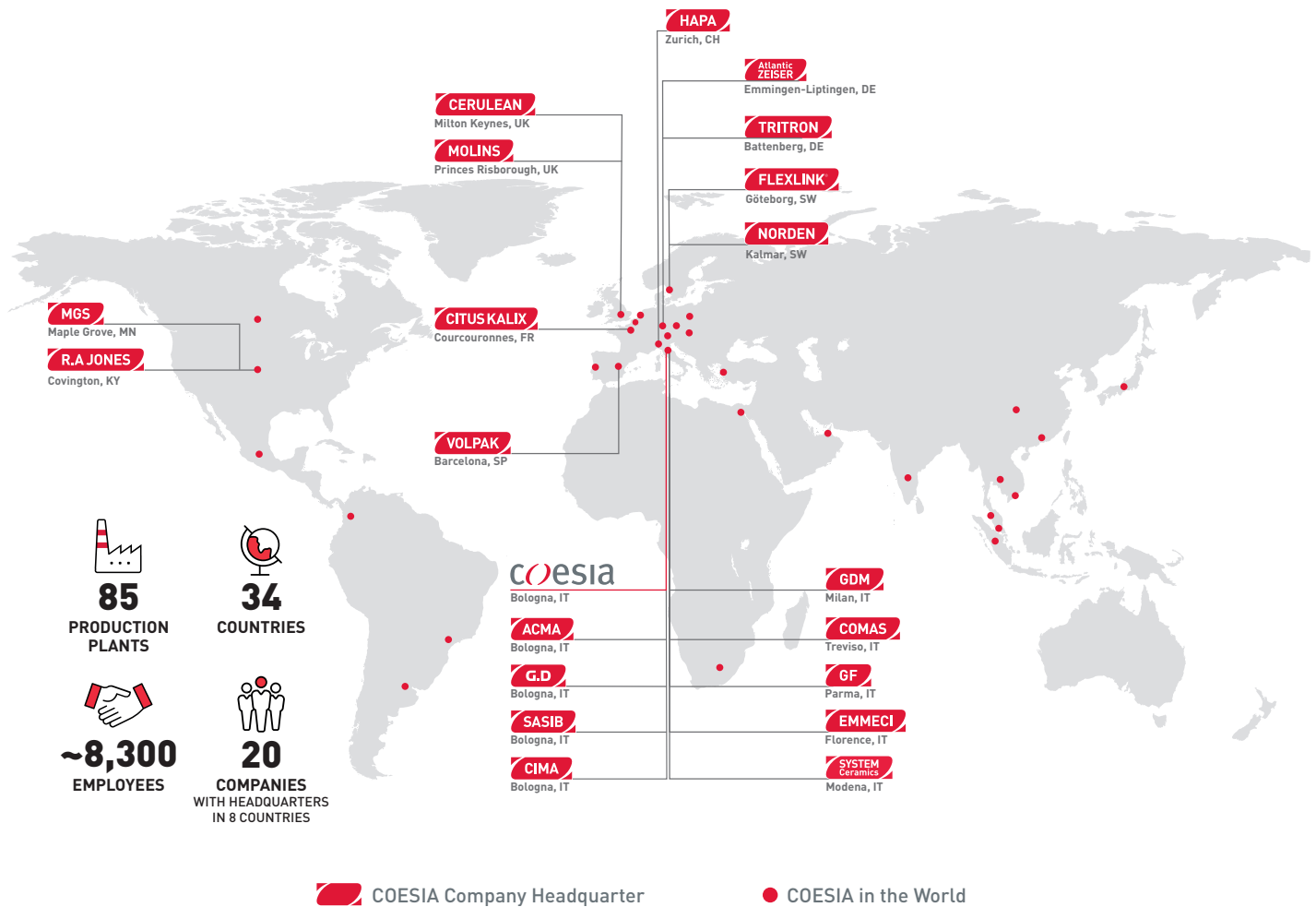

COESIA is a group of innovation-based industrial and packaging solutions companies operating globally, headquartered in Bologna, Italy.

Coesia's companies are leaders in the sectors of:

- **Advanced automated machinery**
- **Industrial process solutions**
- **High-performance transmissions**

Coesia's customers are leading players in a broad range of industries, including Consumer Goods, Tobacco, Healthcare, Aerospace, Racing & Automotive and Electronics.

R.A JONES
 2701 Crescent Springs Road
 Covington, KY 41017 / USA
 T: 1.800.216.4499
www.rajones.com - info@rajones.com



www.rajones.com